

Ultrapac HED/ALD/MSD Type 0005 to 1000

Complete purification package with heatless adsorption dryer, pre-, afterfilter and level-controlled electronic condensate drain.

Compressed air is lead through the inlet of the dryer (J) and across the prefilter (3). At this stage, the air is cleaned from particles and condensate. The condensate is removed via the level-controlled electronic condensate drain (11).

Via the lower shuttle valve (9), the air is lead into the adsorption vessel (1), in which the air is dried down to the required dewpoint. Via the upper shuttle valve (9), the air is let into an afterfilter (4), in which possibly released particles from the desiccant bed are retained. Via the outlet (O), the clean and dry air is lead into the compressed air network and to the point of use.

While one vessel is in the drying phase (adsorption), the other vessel is being dried again (regeneration).

A partial stream of dried air is expanded to atmospheric pressure via a nozzle (6) and lead across the desiccant bed for regeneration and via a solenoid valve (5) and a silencer (7) to the atmosphere.

Ultrapac
HED/ ALD/ MSD

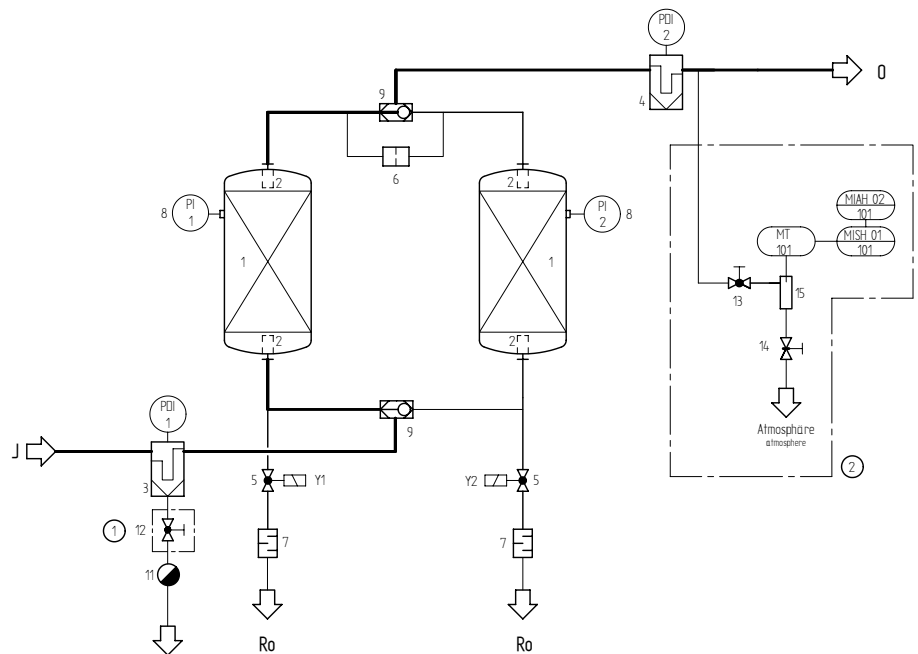

Ultrapac HED/ALD/ MSD	Volume flow in m ³ /h (1 bar, 20°C)*	Regeneration air losses (average) m ³ /h (1 bar, 20°C)			Volume flow out (min.) m ³ /h (1 bar, 20°C)			Pressure loss initial mbar	Prefilter (Afterfilter) MF (PE)
		HED	ALD	MSD	HED	ALD	MSD		
0005	5	0.7	0.8	1	4.1	4.0	3.8	50	03/05
0010	10	1.4	1.5	2	8.3	8.2	7.5	60	03/05
0015	15	2.1	2.3	3	12.4	12.2	11.3	90	03/05
0025	25	3.5	3.8	5	20.7	20.3	18.9	90	04/10
0035	35	4.9	5.3	7	29.0	28.5	26.4	100	04/10
0050	50	7.0	7.5	10	41.4	40.8	37.7	90	05/20
0080	80	11.2	12.0	16	66.2	65.2	60.3	110	05/20
0100	100	14.0	15.0	20	82.8	81.6	75.4	120	05/25
0150	150	21.0	23.0	30	124.2	121.7	113.1	170	05/25
0175	175	24.5	26.3	35	144.9	142.7	132.0	100	05/25
0225	225	31.5	34.0	45	186.3	183.2	170.0	125	07/30
0300	300	42.0	45.0	60	248.3	244.7	226.2	160	07/30
0375	375	52.5	56.0	75	310.4	306.1	282.8	190	07/30
0550	550	77.0	83.0	110	455.3	447.9	414.7	180	10/30
0650	650	91.0	98.0	130	538.1	529.5	490.1	220	10/30
0850	850	119.0	128.0	170	703.6	692.6	640.9	260	15/30
1000	1000	140.0	150.0	200	827.8	815.5	754.0	180	20/30

* related to 1 bar (abs) and 20 °C at intake of compressor and 7 bar (g) and 35 °C inlet temperature

HED/ALD/MSD 0005-1000

Features HED/ ALD/ MSD:	Benefits
Purification package complete with pre-,afterfilter and condensate drain	Turnkey system, no additional installation required, all components from one hand, technically perfectly matched to each other
Prefilter with electronic, level-controlled drain UFM-T	No compressor air losses due to condensate removal, therefore reduction of operating costs
All dryers in cabinet construction	Optimum protection against mechanical damage and against dirt
Generous dimensioned filters	Large filtration surface, therefore low pressure drop and low operating costs
Display of operating status by LED	High operating safety, since all operating status can be detected easily at any time
Intermittent operation standard	Link between dryer and compressor possible on central applications, therefore saving of compressed air
17 sizes available, matched to the compressor flows, with 3 pressure dewpoints each, for choice	Custom made solutions possible, matching exactly customer's requirements; no oversizing of compressors necessary, since lowest possible regeneration air requirements
Comprehensive option package: Dewpoint depending control, start-up device, bypass, pneumatics control, change-over control etc.	Flexibility in application, well thought-o package for economical operation and safe system installation in the compressed air network

Product description:
Ultrapac HED/ALD/MSD: Complete purification package with heatless adsorption dryer, which works on the basis of pressure swing adsorption, with integrated pre- and afterfilter and electronic, level controlled condensate drain

Medium:
Compressed air/ nitrogen

Pressure dewpoint:
HED: -20 °C, ALD: -40 °C, MSD: -70 °C at 100% load

Operating pressure:
min. 4 bar (g), max. 16 bar (g)

Medium temperature:
max. +50 °C

Ambient temperature:
min. +4 °C, max. +50 °C

Power supply:
230 V/ 115 V AC/ 50 – 60 Hz, 24 V DC

Power consumption:
approx. 40 W

Pressure vessel – design, manufacture, testing:
Absorber: acc. to 87/404/EEC Filter: acc. to 97/23/EC

Declaration of conformity:
Type 0005 – 1000: acc. to 73/23/EEC

Sizing:

Operating pressure bar (g)	4	5	6	7	8	9	10	11	12	13	14	15	16
Correction factor overpressure (f_p)	0.63	0.75	0.88	1.0	1.12	1.25	1.38	1.50	1.63	1.75	1.88	2.0	2.13

Type	Pressure-Dewpoint	Residual water content	Inlet temperature °C	20	25	30	35	40	45	50
HED	-20°C	0.88 g/m ³	Correction factor HED Temperature (f_T)	-1.2	1.2	1.1	1.0	-	-	-
			Pressure dewpoint (°C)	-20	-20	-20	-20	-	-	-
ALD	-40°C	0.11 g/m ³	Correction factor ALD Temperature (f_T)	-1.2	1.2	1.1	1.0	-	-	-
			Pressure dewpoint (°C)	-40	-40	-40	-40	-	-	-
MSD	-70°C	0.0027 g/m ³	Correction factor MSD Temperature (f_T)	-1.0	-1.0	1.0	1.0	0.8	0.7	0.5
			Pressure dewpoint (°C)	-70	-70	-70	-70	-65	-55	-50

$$\dot{V}_{corr} = \frac{\dot{V}_{nom}}{f_p * f_T}$$
 Example:
 $\dot{V}_{nom} = 200 \text{ m}^3/\text{h}$, inlet temperature = 30°C, operating pressure = 10 bar (g), PDP -40°C

$$\dot{V}_{corr} = \frac{200 \text{ m}^3/\text{h}}{1.38 * 1.1} = 131.8 \text{ m}^3/\text{h}$$
. Calculated dryer size: Ultrapac ALD, type 0150

HED/ALD/MSD 0005-1000

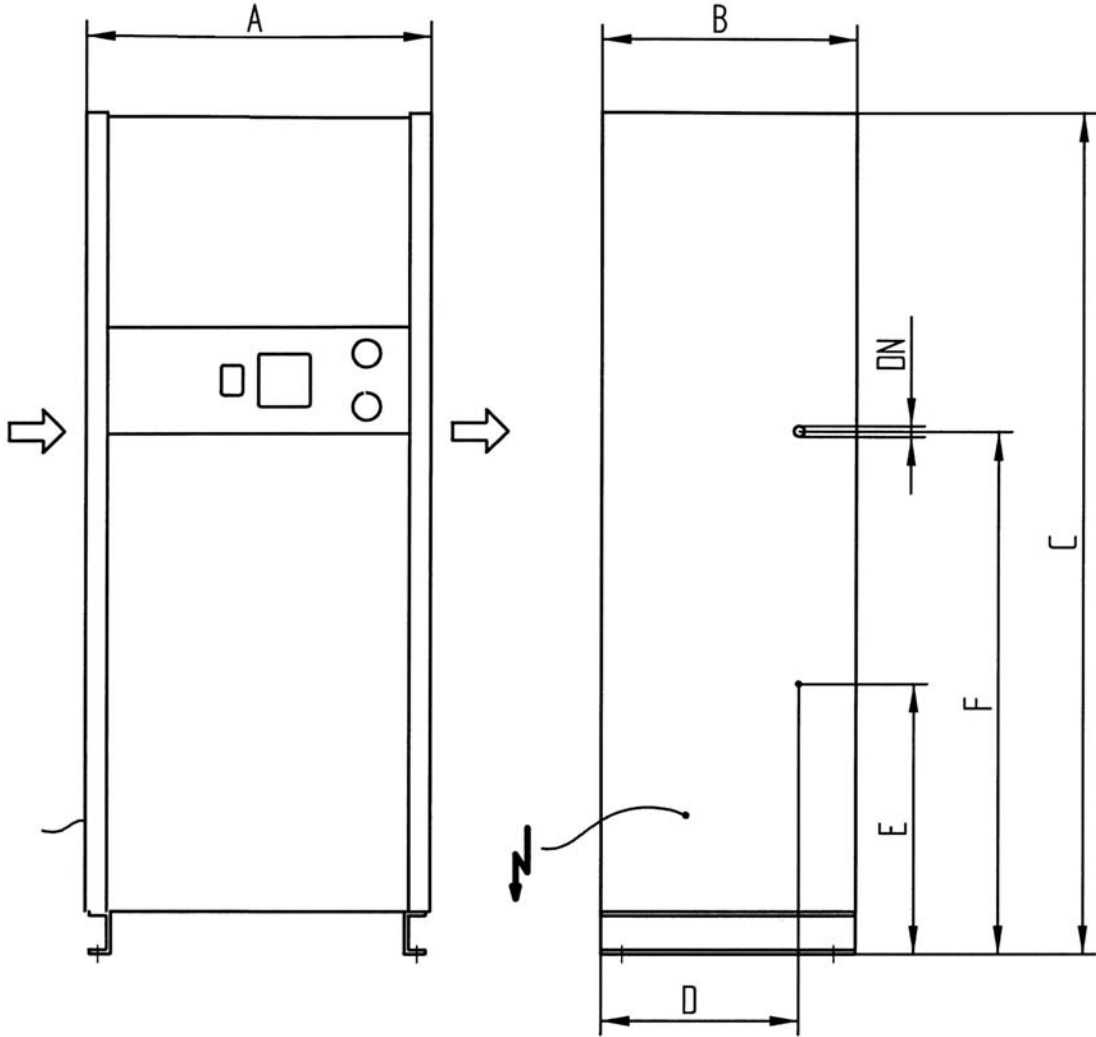

HED/ALD/ MSD	DN "	A mm	B mm	C mm	D mm	E mm	F mm
0005	G 3/8	470	340	700	255	145	440
0010	G 3/8	470	340	700	255	145	440
0015	G 3/8	470	340	1060	255	310	700
0025	G 1/2	470	340	1060	255	310	700
0035	G 1/2	470	340	1060	255	310	700
0050	G 3/4	670	450	1610	315	415	900
0080	G 3/4	670	450	1610	315	415	900
0100	G 1	670	450	1610	315	415	900
0150	G 1	770	600	1980	465	535	1125
0175	G 1	770	600	1980	465	535	1125
0225	G 1 1/2	770	600	1980	465	535	1125
0300	G 1 1/2	770	600	1980	465	535	1125
0375	G 1 1/2	950	700	2190	530	660	1250
0550	G 2	950	700	2190	530	660	1250
0650	G 2	950	700	2190	530	660	1250
0850	G 2	1100	800	2350	650	650	1500
1000	G 2 1/2	1100	800	2350	650	650	1500