

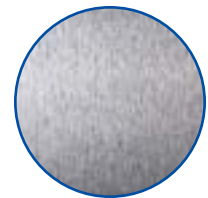

DeVilbiss SRi™ HVLP Spray Gun

DeVilbiss SRi™ HVLP Spray Gun

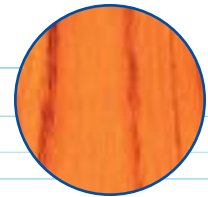
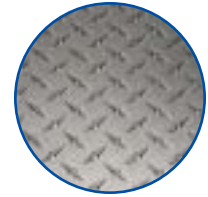

Fine Atomization & Spot Repair Versatility

Finally – a spot repair spray gun with the control needed for spot repairs plus the comfort of a full-size spray gun. The DeVilbiss SRi™ is the ultimate spot repair spray gun with the fit and feel of a full size spray gun combined with the pattern range and versatility needed for invisible, top quality spot repairs. Ideal for production environments where spot repairs are necessary, the DeVilbiss SRi™ is the best choice for comfort, balance, and superior atomization/spray performance.

Maximum Control Means Maximum Performance

- Small gun proportions
- Ergonomically styled for operator comfort
- Full fan and spot patterns for spray versatility
- Full size air and fluid controls
- Cheater valve for precision air adjustments at the spray gun
- Single finger trigger adjusts from fine feathering to fade-outs
- Uniform material distribution

Simple Design For Easy Use & Low Maintenance

- Disposable cups thread into the gun body – no gaskets, seals, or stripped threads
- Color coded, drip free lids for quick, easy material identification
- Special polyethylene seal behind the air cap eliminates overtightening
- Durable, drop forged aluminum body

DeVilbiss SRi™ HVLP Spray Gun

DeVilbiss SRi™ Gravity Feed Spot Repair

Model No.	Fluid Tip (mm)	Inlet Air Pressure	Applications
SRi-628-10	1.0*	20-29 psi	Spot repairs
SRi-628-1.2	1.2*	20-29 psi	Panel repairs, Door jambs

Includes: 1.0 mm fluid tip or 1.2 mm tip, 4 oz. disposable cup and lid, Wrench (SRi-50), Spray lube (SSL-10)

Specifications: 29 psi air inlet pressure delivers 10 psi air cap pressure at 4.5 cfm air volume required. (SRi-5033-205) Air Cap test Kit (Order separately) Provides consistent setup and regulatory proof of air cap pressure.

* Note: For finer control at lower fluid flows, order the optional .8 mm tip and needle separately

Technical Specifications

Maximum Air Pressure:	100 psi (7 bar)
Gun Body:	Anodized Aluminum
Nozzle and Needle:	Stainless Steel
Cup:	Nylon
Cup Lid:	Polypropylene
Air Inlet Size:	Universal 1/4" BSP and NPS(M)
Gun Weight:	13.7 oz.
Gun Repair Kit:	SRi-426

Refer to Service Bulletin: SB-2-525

DeVilbiss SRi™ HVLP Spray Gun

Views showing correct Air Cap/Retaining Ring assembly

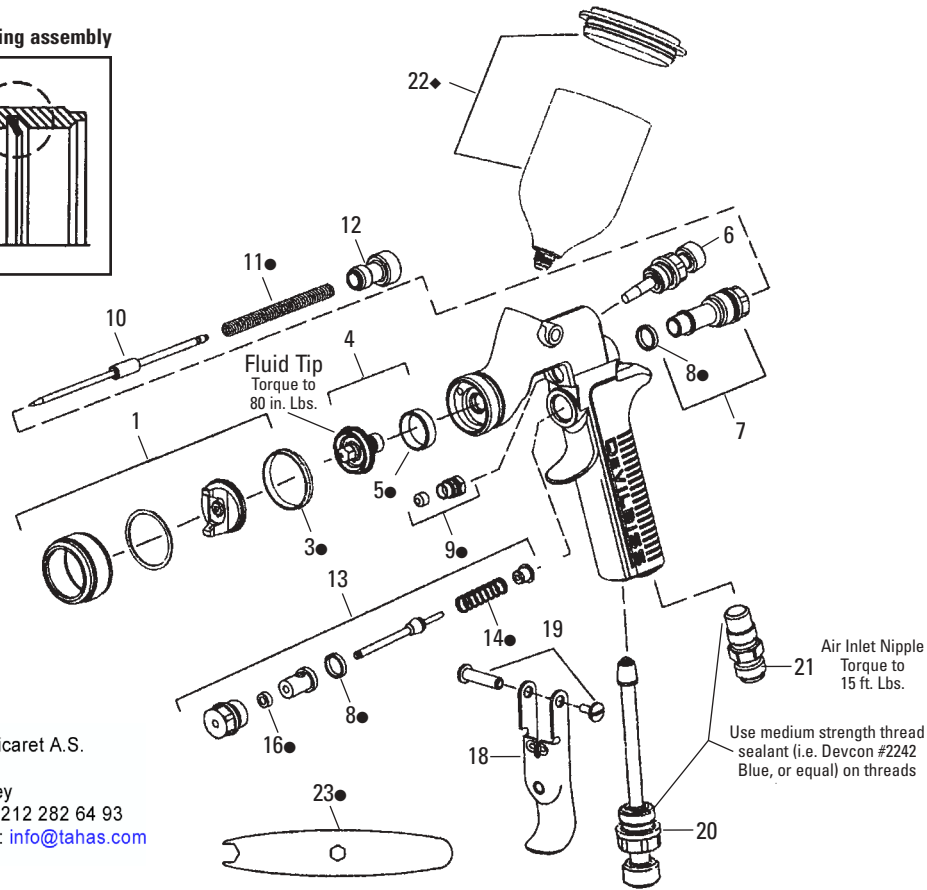
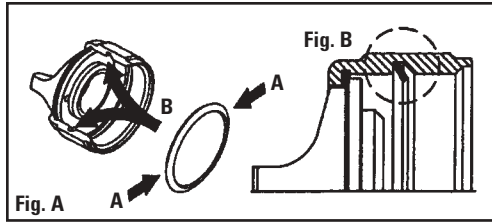

TAHAS Tazyikli Hava Sanayi ve Ticaret A.S.
I. Karaoglanoglu Cad. No: 25/4
34418 Seyrantepe, Istanbul Turkey
Tel: +90 212 284 93 33 Fax: +90 212 282 64 93
Web Site: www.tahas.com E-Mail: info@tahas.com

Customer Service 1.800.992.4657

Ref. No.	Model No.	Description	Ind. Parts Required
1	See Chart 1	Air Cap/Retaining Ring-HVLP	1
•3	SRI-35-K5	Air Cap Seal Kit (5)	1
4	See Chart 1	Fluid Tip	1
•5	SRI-6-K5	Separator Kit (5)	1
6	SRI-401-K	Spreader Valve Assy.	1
7	SRI-17-K	Body Bushing Kit	1
•8	SRI-16-K5	Seal Kit (5)	2
•9	SRI-411-K3	Needle Packing Kit (3 Packings and 1 Nut)	1
10	See Chart 1	Fluid Needle	1
•11	SRI-18-K2	Needle Spring Kit (2)	1
12	SRI-19-K2	Needle Adjusting Knob Kit (2)	1
13	SRI-404-K	Air Valve Assembly	1
18	SRI-9-K	Trigger (SRi)	1
19	SRI-412-K	Trigger Stud and Screw Kit	1
20	SRI-402-K	Air Control Valve	1
21	SRI-20-K	Air Inlet Adaptor	1
◆22	SRI-478-K12	Cup and Lid	1
•23	SRI-50-K2	Wrench SRi (2)	1

• SRI-426 Gun Repair Kit includes a quantity of necessary parts. (Order separately)

Spare Parts & Recommended Accessories

◆ Pack of 12 DeVilbiss SRi™ disposable gravity cups and 12 color coded lids (4 each of red, yellow, and green)	SRI-478-K12
Service Kit – contains seals, springs, needle packing, gun oil	SRI-426
Wrench	SRI-50-K2
Cleaning Brush	42884-214-K5 (3/8") 42884-215-K10 (5/8")
Gun Mounted Regulator	HAV-501
Lubricant	SSL-10-K12
4 oz. Aluminum Cup with Lid	54-4458
Gun Holder	54-4350

Air Cap, Fluid Tip & Needle Chart #1

With SRI-407-205 HVLP Air Cap

Fluid Tip Size (mm)	Fan Pattern Size (mm)
1.0 or 1.2	1/4" - 6 inches max

Fluid Tip Model No.	Fluid Needle Model No.	Tip Size I.D.	
		In.	mm
SRI-2-08-K (optional) ❖	SRI-37	.031	0.8
SRI-2-10-K ❖	SRI-3	.039	1.0
SRI-2-12-K ❖	SRI-3	.046	1.2

❖ Includes (1) SRI-6 Fluid Tip Seal

NOTE: Gun Repair Kit SRI-426 Contains:

Ref. No.	Description	Qty.	Ref. No.	Description	Qty.
3	Air Cap Seal Kit	1	11	Needle Spring Kit	1
5	Separator Kit	1	14	Air Valve Spring	1
8	Seal Kit	2	16	Air Valve Seal	1
9	Needle Packing Kit	1	23	Wrench	1



World Headquarters
ITW Industrial Finishing
DeVilbiss
195 Internationale Blvd.
Glendale Heights, IL 60139
630-237-5000
Fax 630-237-5011
www.devilbiss.com

