

Unimaster® Dust Collectors



Unimaster®

Filtration Engineered for Performance

The Unimaster® dust collector from Donaldson® Torit® is designed to maximize dust collection and the life of collector components for years of extended service. In production for over 40 years with hundreds of thousands in use worldwide, the Unimaster collector's compact design and quiet operation is an industry success. Yet, Donaldson Torit is continually improving the Unimaster to ensure that it provides efficient, trouble-free service.

A self-contained collector with everything needed to begin collecting dust, the Unimaster comes complete with fan and fan motor, automatic shaker and shaker motor, and system controller making installation quick and easy. Since the automatic shaker cleans the filter bags, there is no need for expensive compressed air. Ideal for intermittent operations in plant processes, the Unimaster can be used as a central system or at the point of dust generation.

*40 Years
of Proven Performance*

Unimaster Offers:

- **Compact design** Minimizes floor space and fits in virtually any plant layout.
- **Versatility** Three configurations to suit a variety of dust collection applications.
- **Broad range** Offering maximum air handling capacity in a compact design, the Unimaster offers filtration media area from 40 to 750 square feet.
- **Quiet & efficient operation** Motors and fan are enclosed in collector housing to minimize noise.
- **Easy maintenance**
- **10-year warranty**



UMA 100

Sizes & Operations

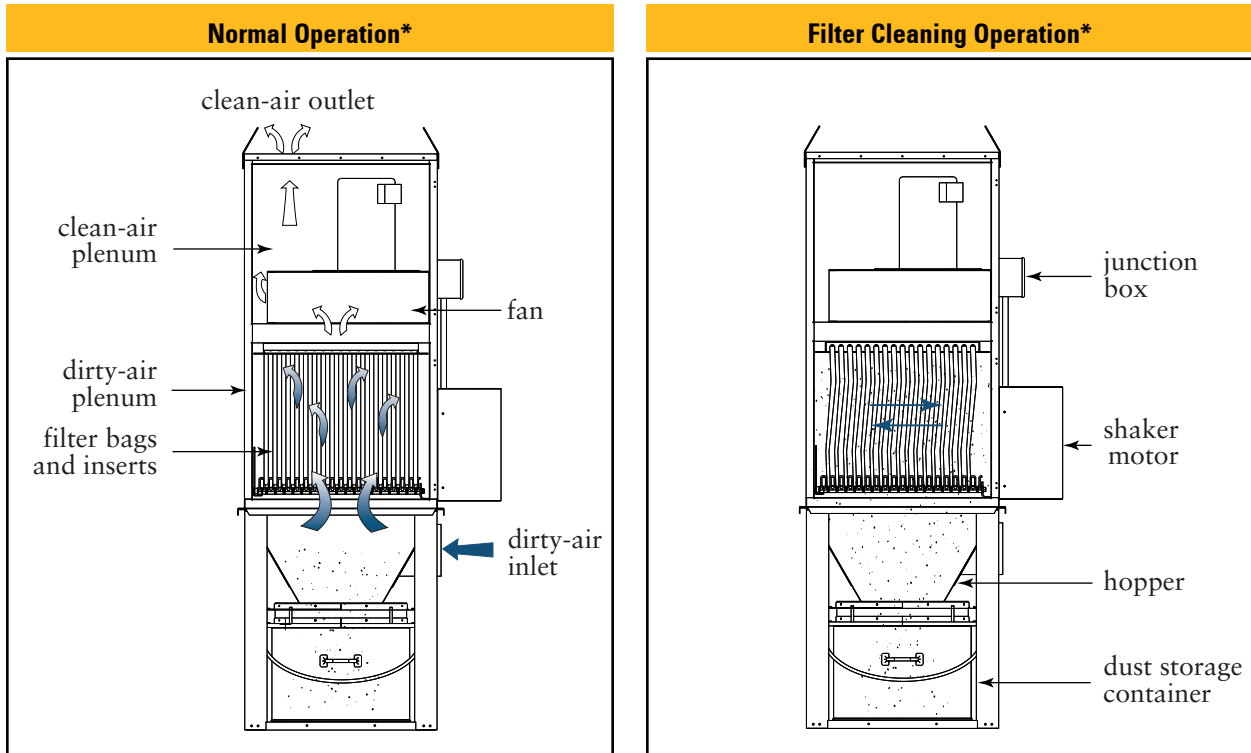

* Doors not shown on unit for illustrative purposes.

Unimaster Performance

- **Perforated inlet deflector** knocks down larger particles into the hopper reducing bag abrasion and increasing filter bag life.
- **Quick-release lever** allows for easy removal and maintenance of bin.
- **Heavy-duty flexible metal coils** inserted into filter bags keeps bags open to maximize airflow and assist in knocking dust off during cleaning cycle.
- **Bag-release levers** allow for easy removal of bags.

Perforated Inlet Deflector



Quick-Release Lever



Heavy-Duty Flexible Metal Coils



Bag-Release Levers



Dimensions & Specifications

HOPPER BASE

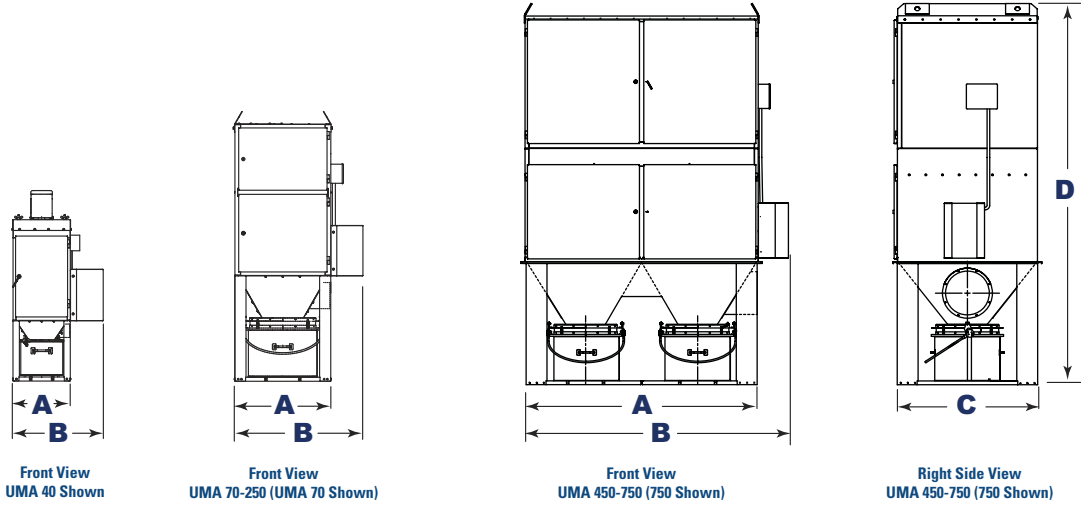

BIN VENT BASE (H-TYPE)

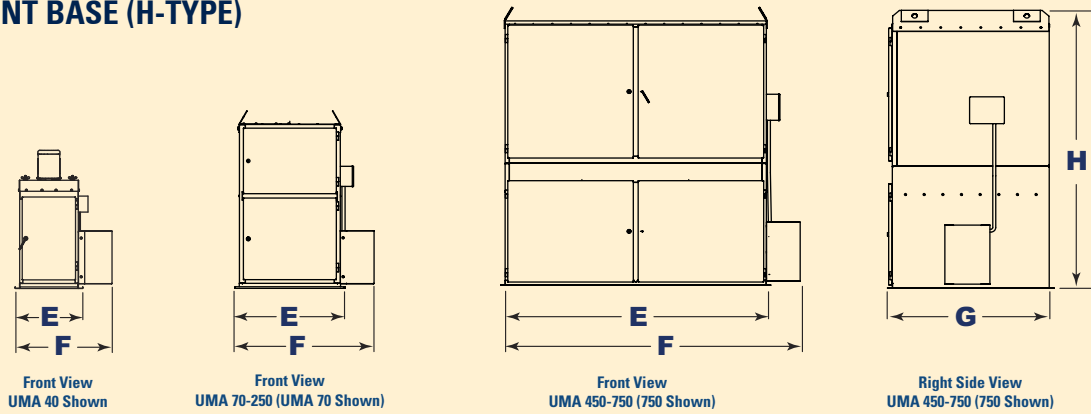

55-GALLON DRUM BASE

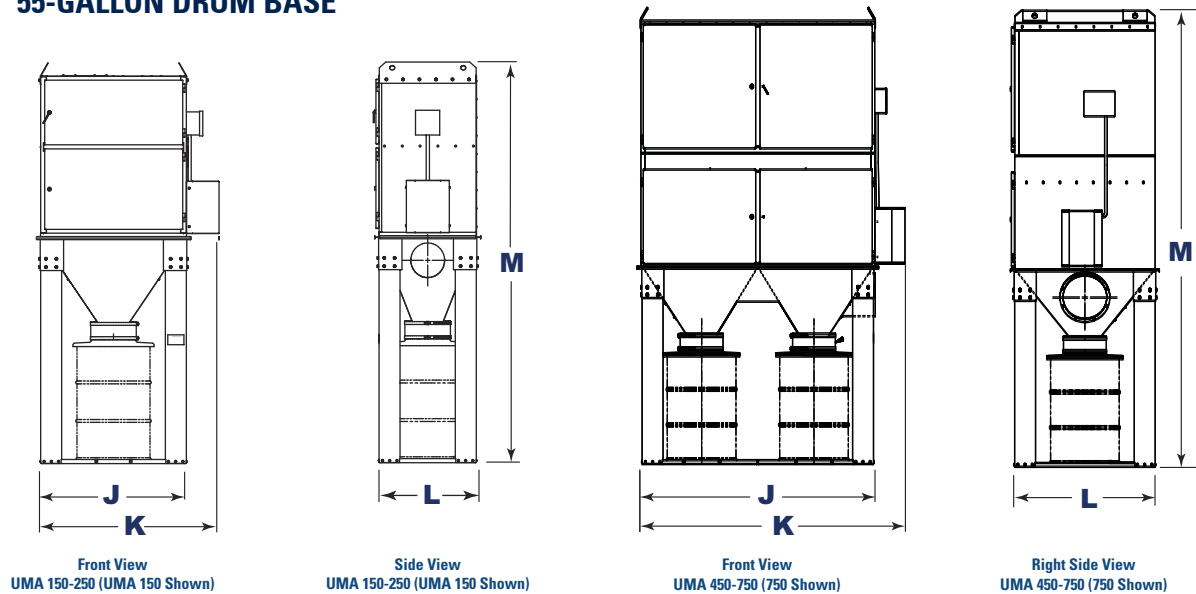

Dimensions & Specifications

Model	Nominal Airflow Range* (cfm)	Cloth Area (ft ²)	No of Filter Bags	No of Bins/Drums**	Inlet Diameter (in)	Shipping Weight (lbs)		
						Hopper Base	Bin Vent Base	55-Gallon Drum Base
40	120-400	40	1	1	4	250	260	N/A
70	200-525	70	1	1	4	230	450	N/A
100	200-1,000	100	1	1	8	440	600	N/A
150	450-2,000	150	1	1	8	500	800	850
250	450-3,000	244	1	1	10	670	1155	1265
450	1,350-5,000	444	2	2	12	1840	1415	1830
750	2,000-10,000	750	2	2	14	2355	1800	3015

* Based on clean filter.

** UMA 40 uses one 0.75 cu ft bin; UMA 70 uses one 2 or 3 cu ft bin (for 3 cu ft bin, add 9-in to height); UMA 100-250 uses one 3 cu ft bin; and UMA 450-750 uses two 3 cu ft bins.

55-gallon drum base available on UMA 150-750. UMA 150-250 uses one drum and UMA 450-750 uses two drums (drums not included).

Model	Dimensions (inches)											
	A	B	C	D	E	F	G	H	J	K	L	M
40	17.6	27.6	17.6	61.2	20.3	27.9	20.3	41.5	N/A	N/A	N/A	N/A
70	22.6	32.7	22.6	88.8	25.4	33.8	25.4	49.5	N/A	N/A	N/A	N/A
100	30.1	40.2	22.6	84.2	32.9	43.0	25.4	50.8	N/A	N/A	N/A	N/A
150	30.1	40.2	30.1	94.5	32.9	43.0	32.9	59.8	32.9	41.6	30.3	121.0
250	45.1	55.1	30.1	105.2	47.8	57.9	32.9	62.2	47.8	56.6	32.9	121.3
450	59.8	70.1	38.1	121.5	63.0	73.1	41.1	80.6	59.8	70.1	38.1	148.4
750	76.3	86.5	47.4	125.9	79.6	89.7	47.4	85.3	76.2	86.5	47.4	150.2

UMA Weighted Sound Pressure Levels

Model	40	70	100	150	250	450	750
With acoustic diffuser* dB(A)	71	70	71	74	74	82	79
Without acoustic diffuser dB(A)	78	N/A**	N/A**	N/A**	N/A**	N/A**	N/A**

Above dB(A) sound levels are an average of measurements taken in a normal industrial area. Sound levels were taken in accordance with Reference Standard ISO 3746:1995, Survey Method, Grade 3. Installed sound levels may vary depending upon measurement location, operating conditions, and installations.

* Sound ratings on UMA 40, 70, 80, 150 and 450 are with the largest available fan. UMA 250 sound rating is with 5 HP K7 fan. UMA 750 sound rating is estimated for the 30 hp TBI fan. For specific fan models, contact Donaldson Torit.

** Acoustic diffuser (silencer) is standard on UMA 70, 100, 150, 250, 450 and 750.

Performance Selections

Flexible Power Offerings The Unimaster offers a variety of power packs to better meet your precise needs. The system performance graphs below show available static performance at the collector inlet with clean filters.

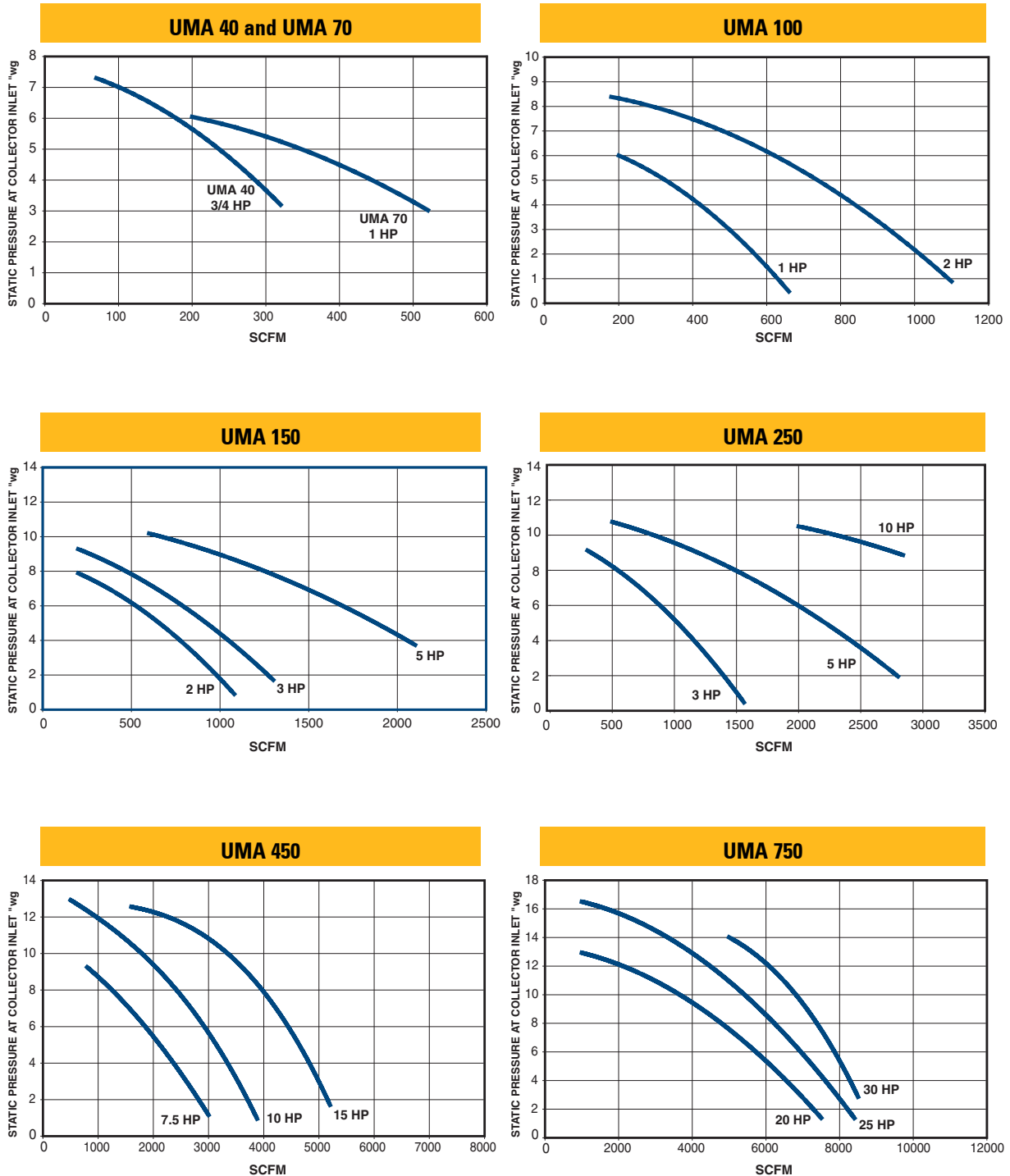

Unimaster®

Standard Features & Equipment Options

	Standard	Optional		Standard	Optional
Collector Design			Hopper Discharge		
Integral Fan and Fan Motor	X		Bin Base with Quick Release Lever		X
Integral TENV Shaker Motor	X		55-Gallon Drum Base		X
Acoustic Diffuser Silencer (70-750)	X		Bin Vent Base		X
Acoustic Diffuser Silencer (40)		X	Electrical Controls, Gauges and Enclosures		
Caster Pack		X	Push-Button Controls	X	
Weatherhood (Weatherbend) Roof		X	Solid-State Timer in Type (NEMA /UL) 12 Enclosure	X	
Various Inlet Locations		X	Motor Starter	X	
Filter Bags			Safety Features		
8 oz. Polyester One-Piece Filter Bags	X		Explosion Vents		X
Anti-Static Filter Bags		X	Sprinkler Taps		X
Variety of Bag Media Options		X	Warranty		
Paint System			10-Year Warranty	X	
Blue Powder Coat Finish (inside and out) Meets 350-Hour Spray Corrosion Protection Test	X				
Custom Color		X			

Proven Performance on Hundreds of Applications



UMA 450
filtering plastic from a CNC machine



UMA 250
on a school wood shop application

* Magnehelic is a registered trademark of Dwyer Instruments, Inc.

Information contained in this document is subject to change without notice.

Cleaner Air Worldwide

Better Technology



- 550 engineers worldwide
- More than 500 patents held by Donaldson employees
- Custom designed solutions

Knowledgeable Service

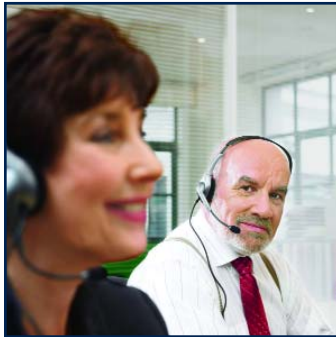

- Broad range of innovative collectors and filters
- Ready-to-ship filters and parts within 48 hours
- Technical expertise and support

Global Support



- Facilities in 35 countries
- 37 manufacturing plants and 11 distribution centers
- 49 sales offices worldwide

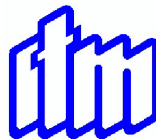

ITM
Muhendislik San. ve Tic. A.S.

I. Karaoglanoglu Etem Zengin Is Merkezi No: 25
34418 Seyrantepe - Istanbul - Turkiye
Tel: +90 212 278 78 12 Fax: +90 212 278 78 11
web site: www.itmfilter.com e-mail: itm@tahas.com



Donaldson®

Filtration Solutions

Donaldson Company, Inc.
Industrial Air Filtration
P.O. Box 1299
Minneapolis, MN
55440-1299 U.S.A.

Tel 800.365.1331 (USA)
Tel 800.343.3639 (within Mexico)
dustmktg@mail.donaldson.com
www.donaldsontorit.com



Printed in USA

**Call Donaldson Torit
to get Cleaner Air today
800-365-1331**

© Donaldson Company, 2006 Unimaster 03-2006